



BAŞKENT 3 RAYDATOR YAĐ SOĐUTUCU



CHR[®]
COOLER HEAT EXCHANGER RADIATOR

1985'den İtibaren
Yađ Sođutucu İmalatı

FANLI YAĐ SOĐUTUCU SERİSİ CHR-İ
CHR-İ SERIES OF FAN OIL-COLOR
HEAT-EXCHANGERS

CHR air-oil heat exchangers are used for cooling oil hydraulic systems using as the coolant ambient air that passes over the radiant by means of a fan operated by an electric or hydraulic motor.

The cooler element, in high resistance aluminium alloy, is obtained by means of a braze-welding process carried out under vacuum.

The particular configuration of the cooling pipes increase the turbulence of the fluid consequently of the exchange capacity; moreover, the presence of special jets on the cooler finning further improves the total transmission coefficient.

The result is a very small, light and robust technologically advanced product.

Compatible fluids

- . MINERAL OILS; HL; HLP.
- . WATER-OIL EMULSION.
- . WATER-GLYCOL.
- . Consults **CHR** for other fluids.

Technical specification of Cooler Element

- . Material: long life aluminium.
- . Operating pressure: 20 bar
- . Test pressure: 35 bar.
- . Max operating temperature: 120°C.
- . For specially aggressive atmospheres contact **CHR**

Installation

The exchangers can be fitted in a horizontal position, respecting the minimum distance from the wall (see fig.1) so as to ensure a natural flow of cooling air.

The exchangers is usually installed on oil tank return piping; it must also be protected from impacts and mechanical vibrations by supports and must be connected to the plant with flexible pipes.

Avoid subjecting the exchanger to sudden changes in flow, hammering and pulsations that can cause irreversible damage to the element.

We recommend installing a by-pass valve (see fig.2) to protect the exchanger from over-pressure generated when the plants is started up due to high oil viscosity.

Maintenance

You should be particularly carefully in cleaning the cooler element to guarantee a natural exchange of air, in order to prevent a reduction in thermal efficiency

Cleaning oil side

The exchanger should be dismantled to clean on the oil side. The dirt can be removed by flushing, in counter-current, de-greasing substance, compatible with aluminium. Wash with hydraulic oil before re-connecting the product to the plant.

Cleaning air side

Cleaning on the air side can be done using compressed air or water, directing the jet parallel to the fins so as not to damage them.

Oily dirt or grease can be removed with a jet of steam or hot water. During this operation, the electric motor must be disconnected from the voltage supply, and must be adequately protected.

Example of how to choose a heat exchanger

Proceed with sizing the exchanger, with a knowledge of the data as the example below shows:

Power to dissipate	:	19,5	[KW]
ISO VG 32 oil flow	:	90	[lpm]
Oil input temperature	:	60	[°C]
Ambient temperature	:	30	[°C]
Fan operating with an electric motor 230/400V-50Hz.			

You can then calculate the specific heat exchange power KW/°C if you know the power to dissipate and the ΔT (the difference between the oil input temperature and the ambient temperature).

$$P = \frac{19,5 \text{ KW}}{60^\circ - 30^\circ} = 0.65 \text{ KW/}^\circ\text{C}$$

Note the oil flow (90 lpm) and specific exchange power (0.65 KW/°C), product research is made by referring to the graph in the catalogue which is relevant to each model.

P/N	V	Hz	kW	A	rpm	ø Fan	dB(A)	(m³/h)	IP	lt	Kg
243003 ###	230-400 B14 AC	50	0,75	3,46-1,90	1394	450	82	4000	55		37
	280-480 B14 AC	60	0,90	3,41-1,99	1673		☑	☑			
243012 ###	12 DC	/	0,115	9,58	2530	280	74	1550	65	6,8	32
243024 ###	24 DC	/	0,125	5,20	2900	280	78	1700	65		32
243056 ###					☑	450	☑	☑	/		35

☑ Teklif isteyiniz.

Performans Şeması / Performance diagram

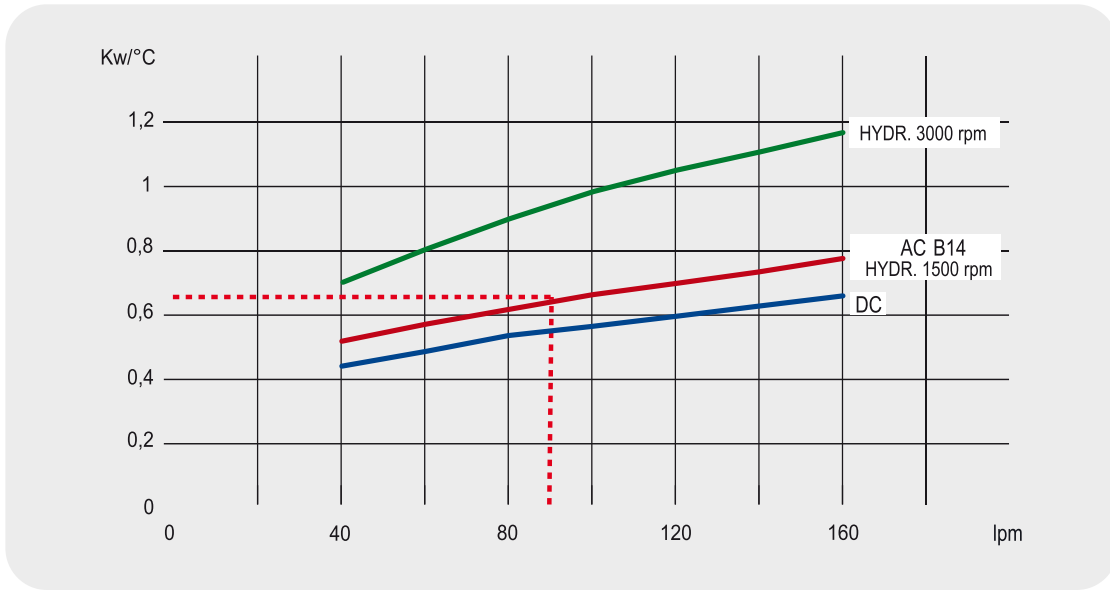

The exchanger selected is the following model:

CHR 30 - 230/400 - 50Hz
cod.243003###.

For a complete description of the exchanger consult the *PRODUCT ORDERING CODE* page.If you do not know all the data required for selecting the model, contact **CHR**

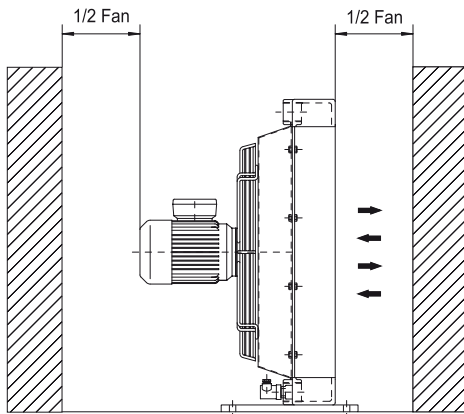

Fig.1

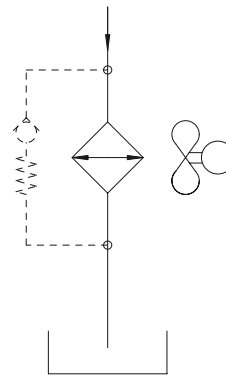
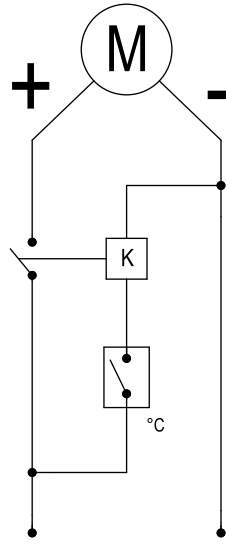
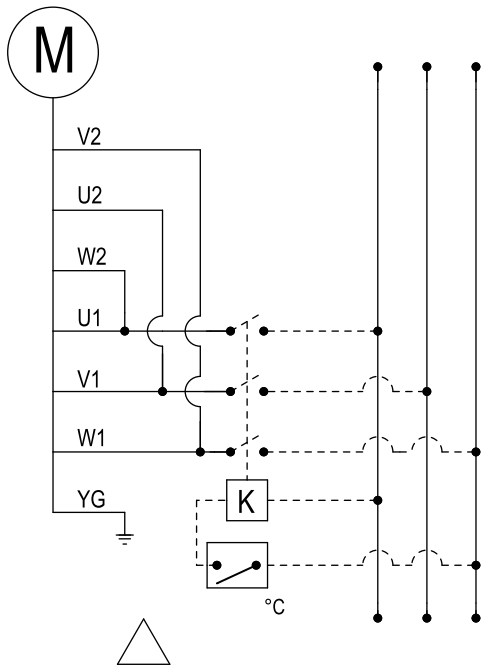

Fig.2

Elektrik Devresi / Electric Wiring



12-24V DC



230V-280V AC 3 PHASE

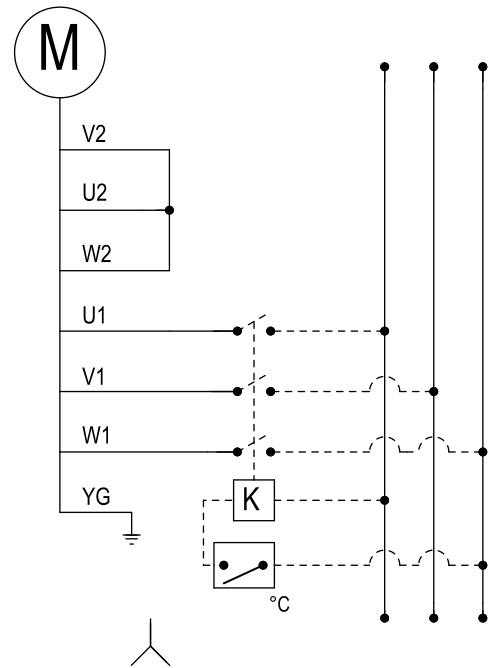

400V-480V AC 3 PHASE

°C = Thermostat No.

K = Relay

Soğutucu Seçimi İçin Levha / Sheet For Cooler Selection

ŞİRKET COMPANY	
İSİM NAME	

Hava-Yağ

YAĞ DEBİSİ OIL FLOW POWER	Imp	
TOPLAM GÜÇ TOTAL POWER	KW	
DAĞITILMASI GEREKEN GÜÇ POWE TO BE DISSIPATED	KW	
Yağ SICAKLIK GİRİŞİ OIL TEMPERATURE INLET	°C	
MAKSİMUM ORTAM SICAKLIĞI MAX AMBIENT TEMPERATURE	°C	
YAĞ VİSKOSİTESİ AKIŞKANLIĞI OIL VISCOSITY	cst	
ÇALIŞMA BASINCI WORKING PRESSURE	bar	

FAN BİRİMİ TİPİ / TYPE OF FAN UNIT

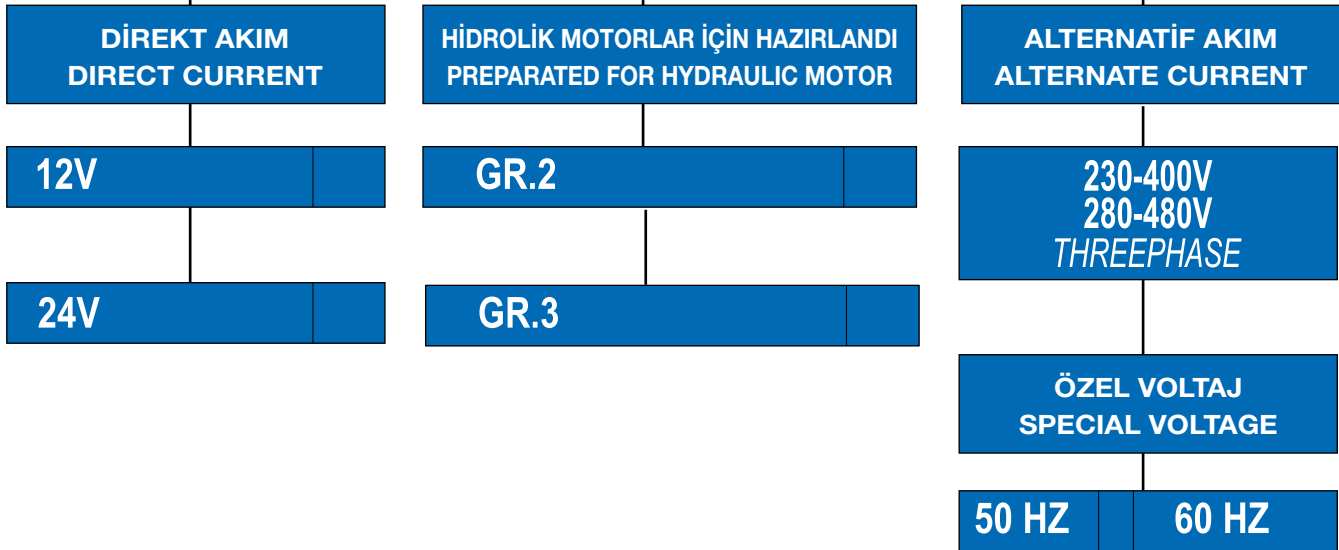

Sipariş Kodu / Ordering Code

2

424

03

2

01

Soğutucu Serileri Cooler Series

424 (CHR 24)

Fan Motoru Tipi Fan Motor Type

03 AC 230V-400V 50Hz / AC 280-480 60Hz (B14)
12 DC 12V
24 DC 24V
56 Pred. per mot. idr. gr.2 Pred. for hydr. mot. gr.2
58 Pred. per mot. idr. gr.3 Prep. for hydr. mot. gr.3

Termostatlar Thermostats

1	Fixed thermostat	40-28°
2	Fixed thermostat	50-38°
3	Fixed thermostat	60-48°
4	Fixed thermostat	70-58°
5	Fixed thermostat	80-68°
6	Fixed thermostat	90-78°
7	Adjustable thermostat	0-90° (TC2)
8	Connected adjustable thermostat	0-120°(TC2)

Havalandırma Tipi Ventilating Type

01 Suction air flow
02 Blowing air flow

CHR Series

CHR 12	pag. 8 - 9
CHR 18	pag. 10 -11
CHR 24	pag. 12 -13
CHR 30	pag. 14 -15
CHR 36	pag. 16 -17
CHR 42	pag. 18 -19
CHR 50	pag. 20 -21
CHR 52	pag. 22 -23



CHR 2pass Series

CHR 24 2 PASS	pag. 24-25
CHR 30 2 PASS	pag. 26-27
CHR 36 2 PASS	pag. 28-29
CHR 42 2 PASS	pag. 30-31
CHR 50 2 PASS	pag. 32-33
CHR 52 2 PASS	pag. 34-35

CHR /2 Series

CHR 30/2	pag. 36-37
CHR 36/2	pag. 38-39
CHR 42/2	pag. 40-41
CHR 50/2	pag. 42-43
CHR 52/2	pag. 44-45
CHR 44/2	pag. 46-47
CHR 44/3	pag. 48-49
CHR 46/2	pag. 50-51
CHR 46/3	pag. 52-53





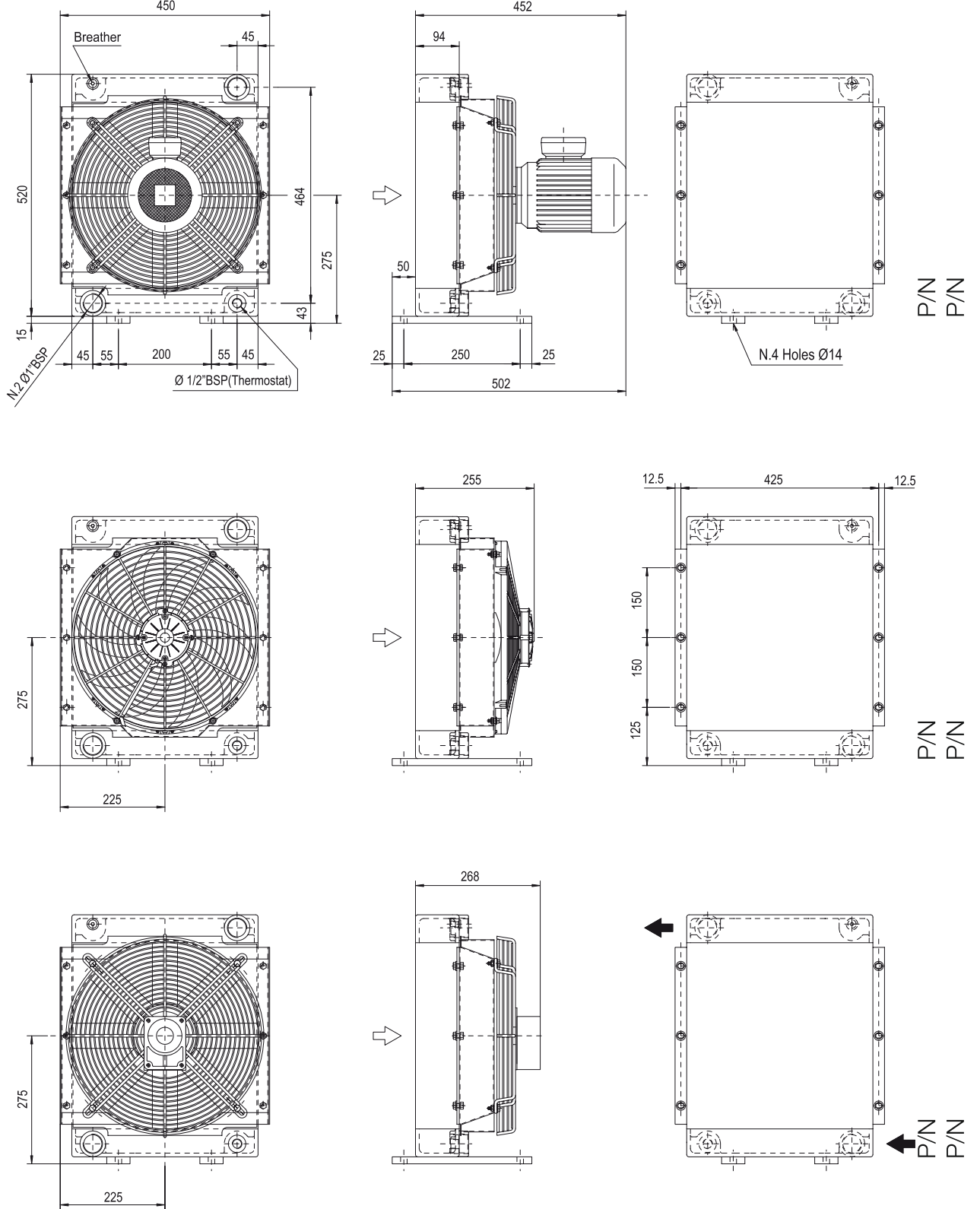



Yağ Soğutucu Boyutları / Dimensions



Boyutlar ve teknik özellikler bağlayıcı değildir.
Over-all dimensions and technical characteristic are not binding

Teknik Veriler / Technical Data

P/N	V	Hz	kW	A	rpm	ø Fan	dB(A)	(m ³ /h)	IP	lt	Kg
	230-400 B14 AC	50	0,55	2,58-1,49	1391	400	79	2800		2,9	28
	280-480 B14 AC	60	0,66	2,56-1,49	1669	400			55		28
	12 DC	/	0,187	15,6	2350	385	77	2100	65		22
	24 DC	/	0,170	7,1	2580	305	80	2250	65		22
						400			/		23

 Teklif isteyiniz.

Performans Şeması / Performance diagram

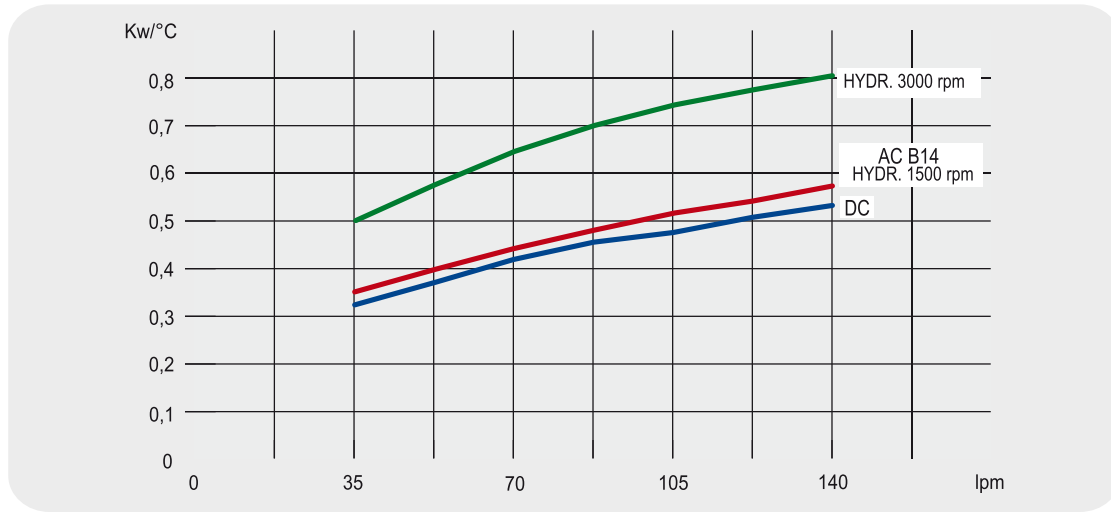



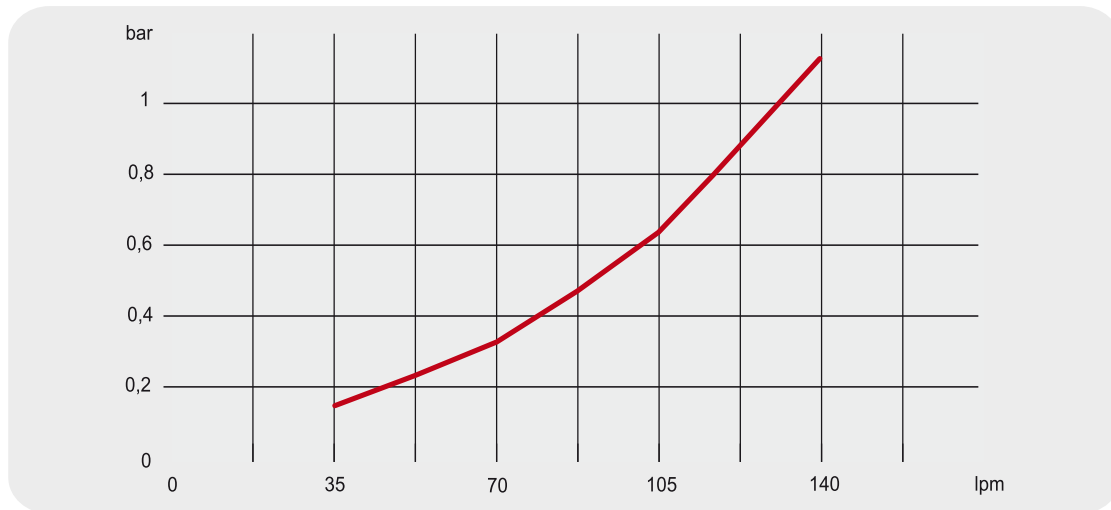

Basınç Düşmesi / Pressure drop (ISO VG 32)



Düzeltilme Faktörü -F- (Basınç Düşmesi) / Correction factor -F- (Pressure drop)

cst	10	15	20	30	40	50	60	80	100	200	300
F	0,5	0,65	0,77	1	1,2	1,4	1,6	1,9	2,1	3,3	4,3

Teknik Veriler / Technical Data

P/N	V	Hz	kW	A	rpm	ø Fan	dB(A)	(m ³ /h)	IP	lt	Kg
	230-400 B14 AC	50	0,75	3,46-1,90	1394		82	4000			
	280-480 B14 AC	60	0,90	3,41-1,99	1673	450			55	6,8	37
	12 DC	/	0,115	9,58	2530	280	74	1550	65		32
	24 DC	/	0,125	5,20	2900	280	78	1700	65		32
						450			/		35

 Teklif isteyiniz.

Performans Şeması / Performance diagram

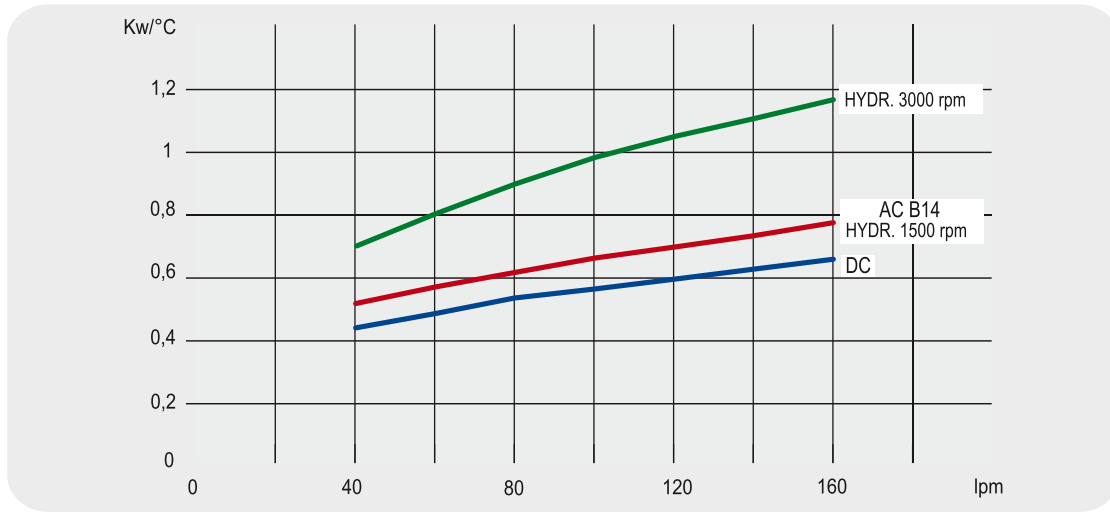

Basınç Düşmesi / Pressure drop (ISO VG 32)

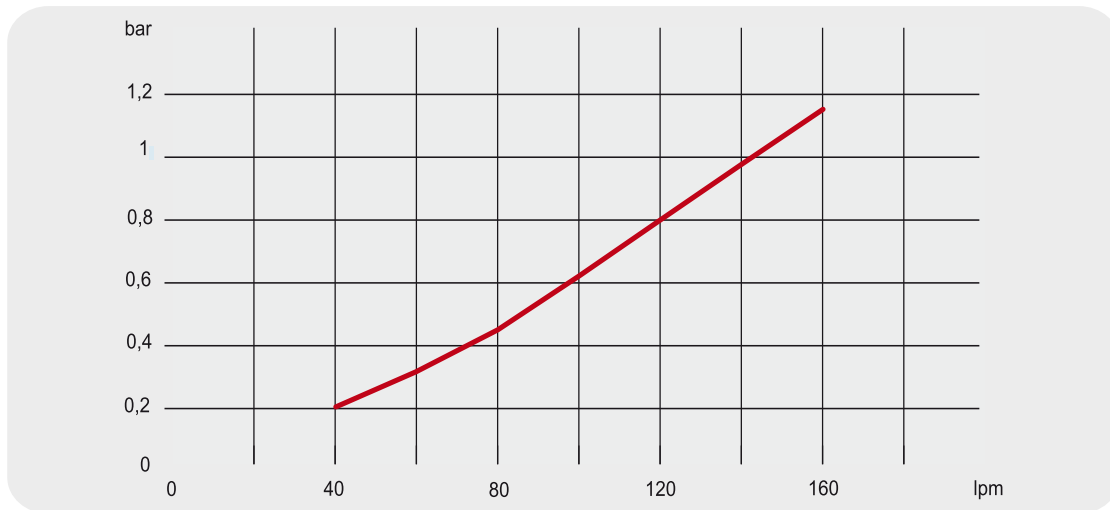

Düzeltilme Faktörü -F- (Basınç Düşmesi) / Correction factor -F- (Pressure drop)

cst	10	15	20	30	40	50	60	80	100	200	300
F	0,5	0,65	0,77	1	1,2	1,4	1,6	1,9	2,1	3,3	4,3

Yağ Soğutucu Boyutları / Dimensions

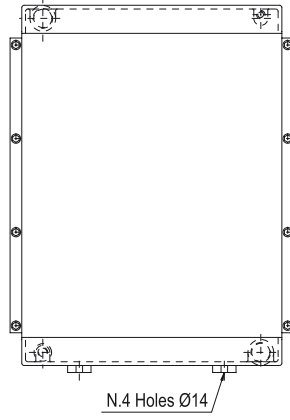
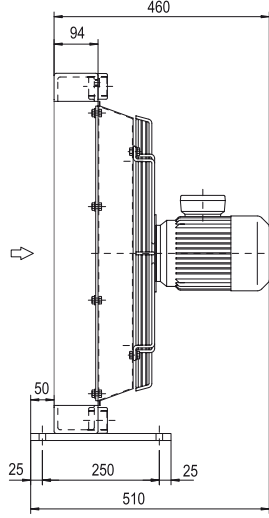
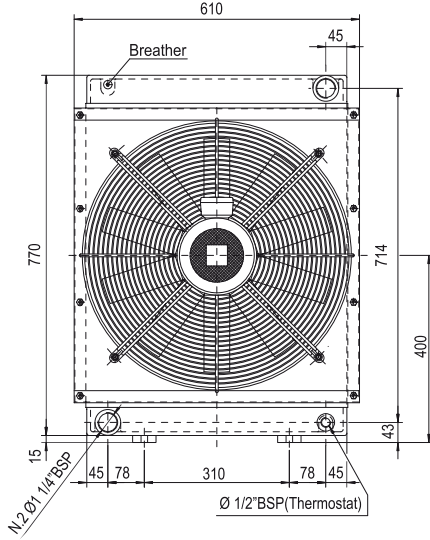

P/N
P/N

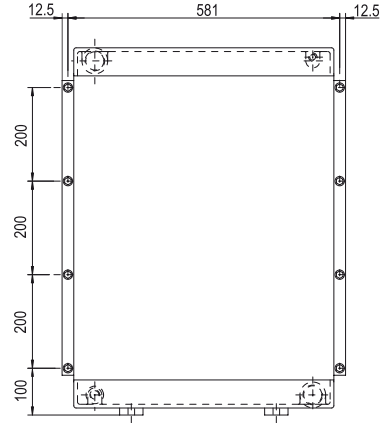
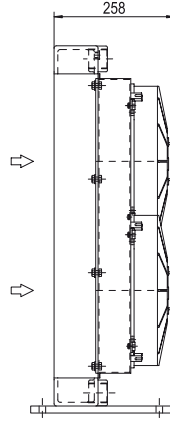
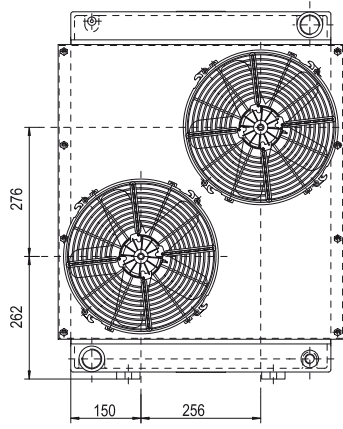

P/N
P/N

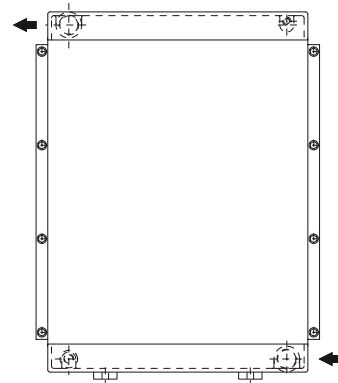
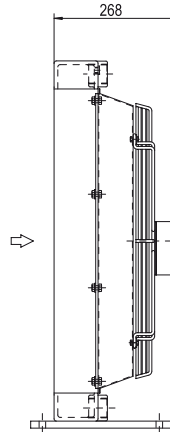
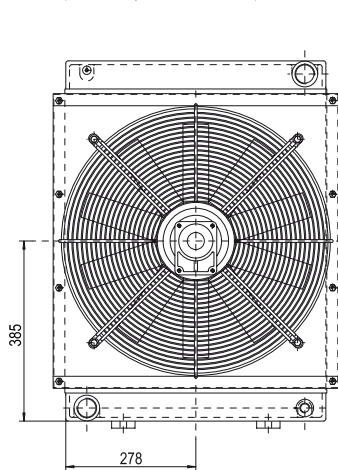

P/N
P/N

Boyutlar ve teknik özellikler bağlayıcı değildir.
Over-all dimensions and technical characteristic are not binding

Teknik Veriler / Technical Data

P/N	V	Hz	kW	A	rpm	ø Fan	dB(A)	(m ³ /h)	IP	lt	Kg
	230-400 B14 AC	50	1,1	4,35-2,50	1378	500	82	5650	55	9,4	60
	280-480 B14 AC	60	1,32	4,29-2,50	1654						
	12 DC	/	0,160	13,30	2560	305	83	2100	64		50
	24 DC	/	0,177	7,35	3000	305	84	2400	64		50
						450			/		52

 Teklif isteyiniz.

Performans Şeması / Performance diagram

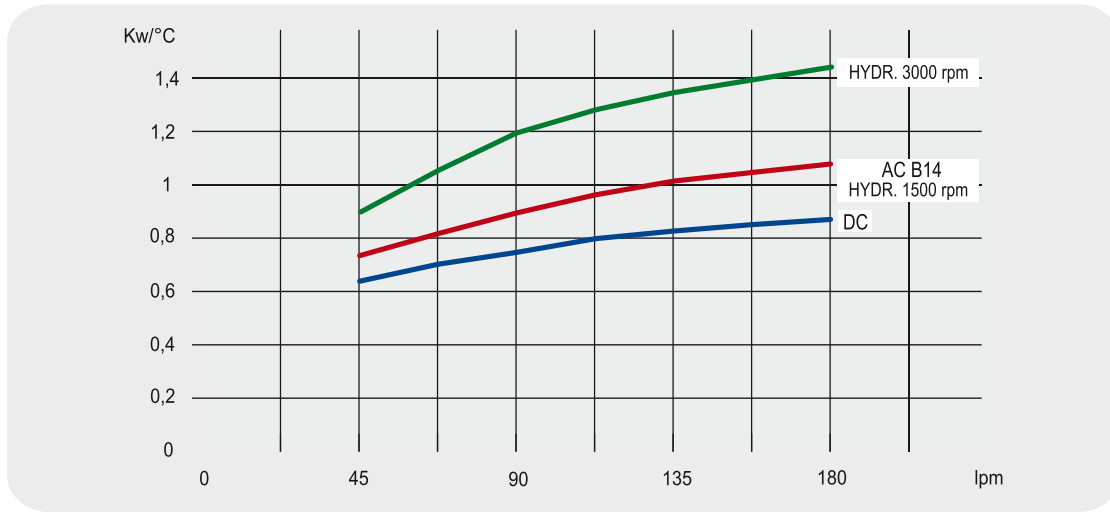

Basınç Düşmesi / Pressure drop (ISO VG 32)

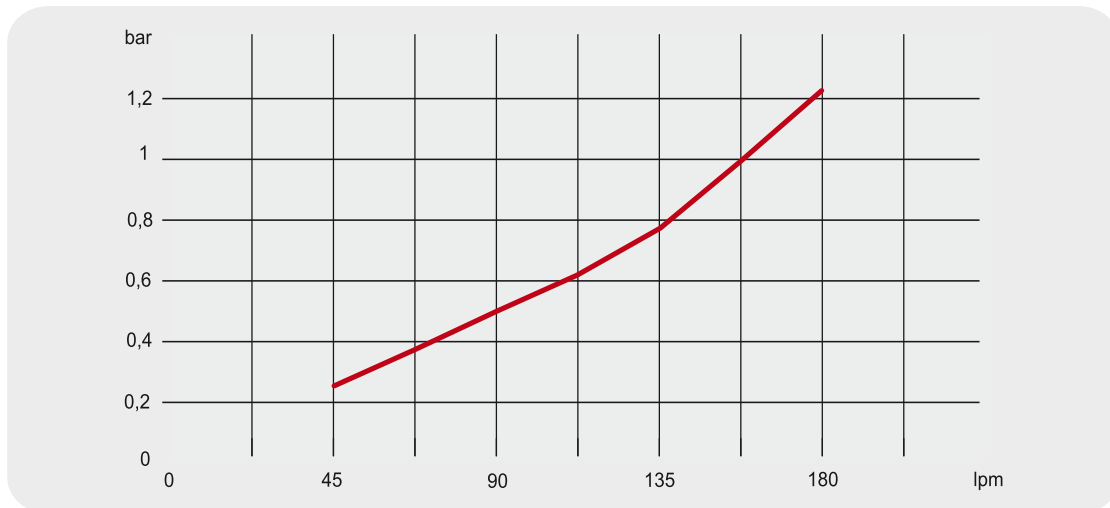

Düzeltilme Faktörü -F- (Basınç Düşmesi) / Correction factor -F- (Pressure drop)

cst	10	15	20	30	40	50	60	80	100	200	300
F	0,5	0,65	0,77	1	1,2	1,4	1,6	1,9	2,1	3,3	4,3

Yağ Soğutucu Boyutları / Dimensions

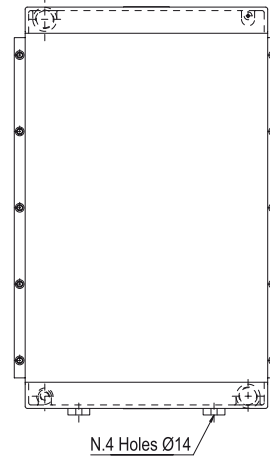
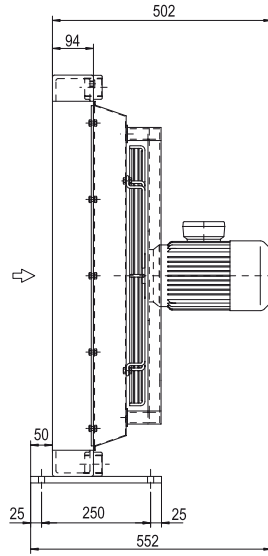
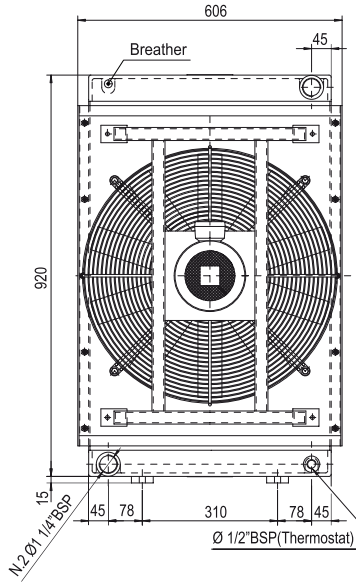

P/N
P/N

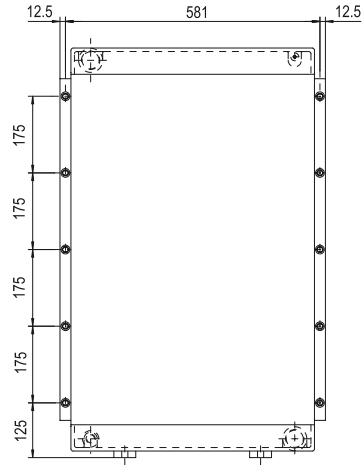
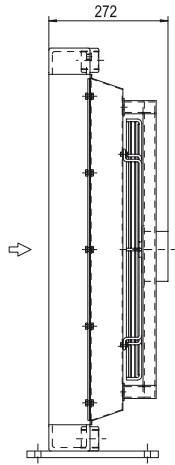
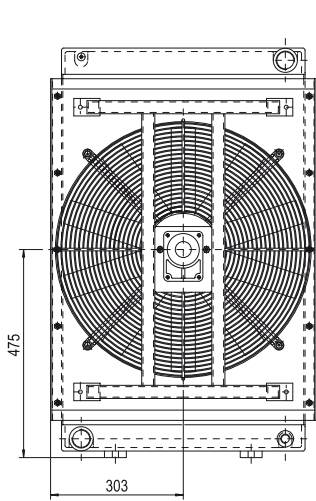

P/N
P/N

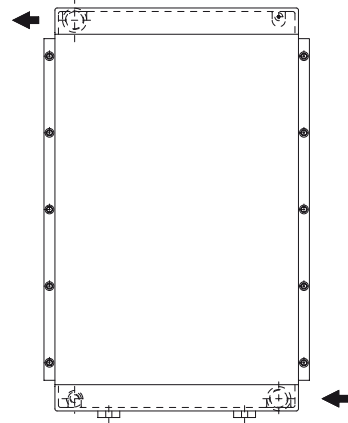
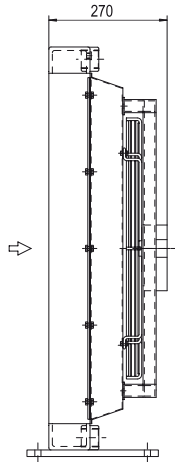
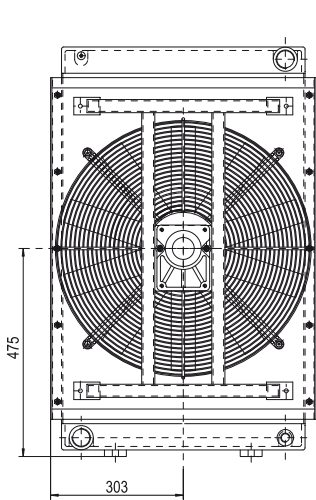

P/N
P/N

Boyutlar ve teknik özellikler bağlayıcı değildir.
Over-all dimensions and technical characteristic are not binding

Teknik Veriler / Technical Data

P/N	V	Hz	kW	A	rpm	ø Fan	dB(A)	(m³/h)	IP	lt	Kg
	230-400 B14 AC	50	1,1	4,35-2,50	1378		84	7550			
	280-480 B14 AC	60	1,32	4,29-2,50	1654	560	☒	☒	55	10,6	65
					☒	560	☒	☒	/		58
					☒	560	☒	☒	/		58

☒ Teklif isteyiniz.

Performans Şeması / Performance diagram

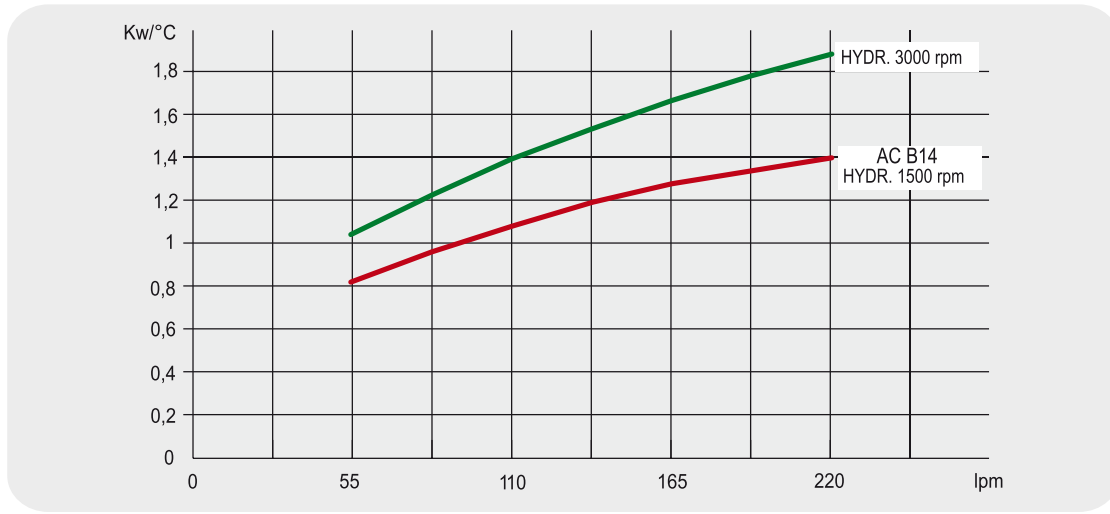

Basınç Düşmesi / Pressure drop (ISO VG 32)

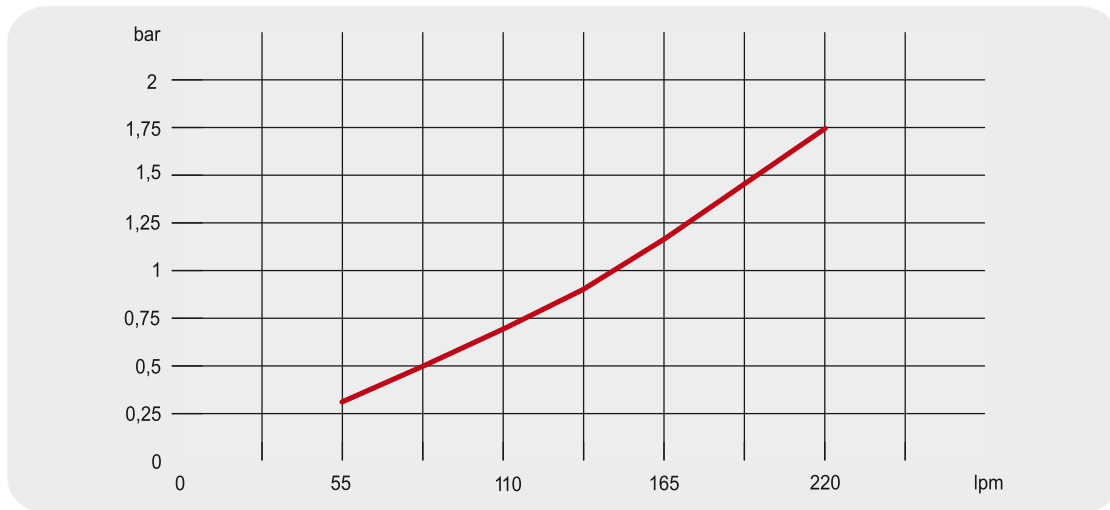

Düzeltilme Faktörü -F- (Basınç Düşmesi) / Correction factor -F- (Pressure drop)

cst	10	15	20	30	40	50	60	80	100	200	300
F	0,5	0,65	0,77	1	1,2	1,4	1,6	1,9	2,1	3,3	4,3



Yağ Soğutucu Boyutları / Dimensions

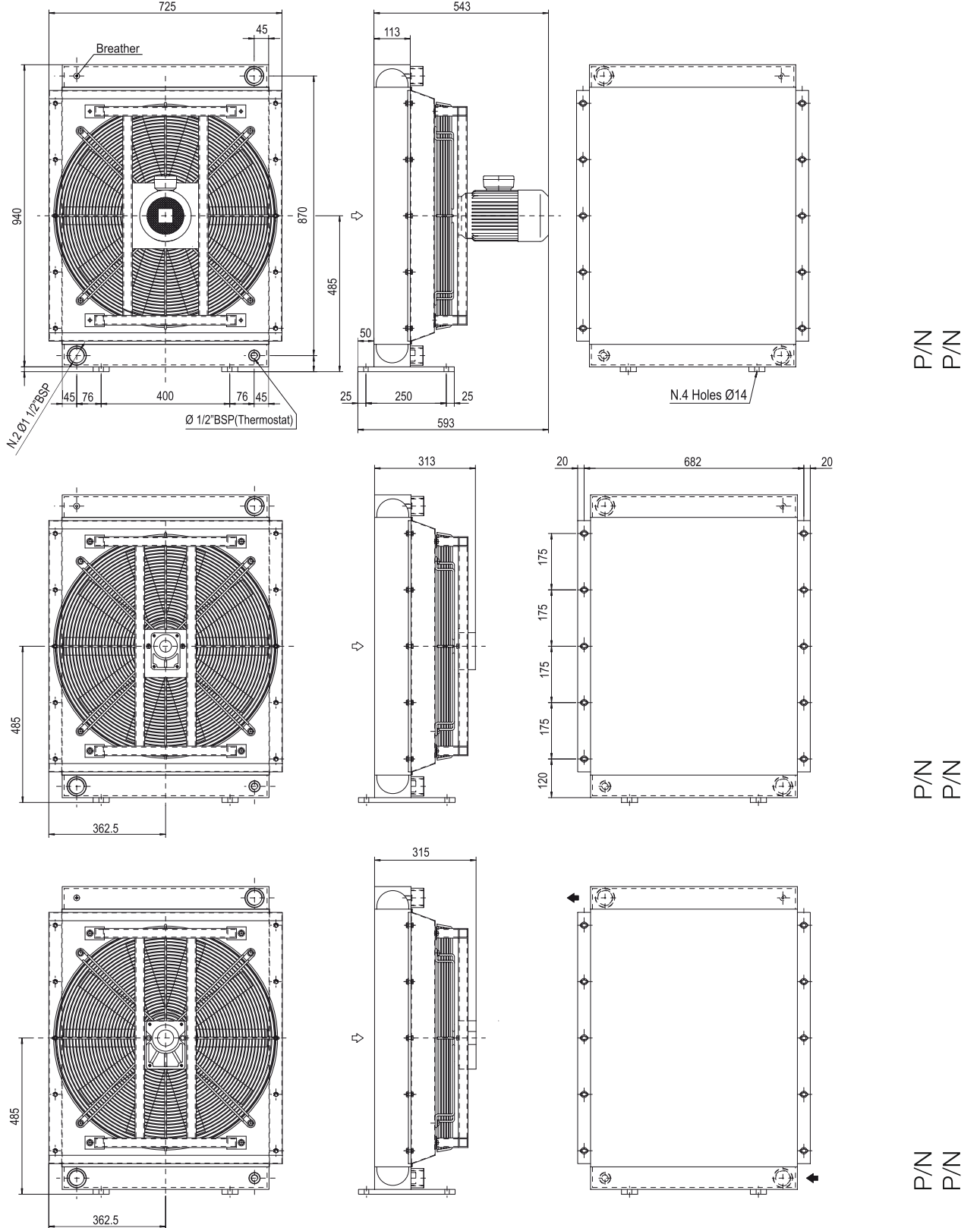

Boyutlar ve teknik özellikler bağlayıcı değildir.
Over-all dimensions and technical characteristic are not binding

Teknik Veriler / Technical Data

P/N	V	Hz	kW	A	rpm	ø Fan	dB(A)	(m³/h)	IP	lt	Kg
	230-400 B14 AC	50	1,1	4,77-2,74	915		80	7550			
	280-480 B14 AC	60	1,32	4,70-2,74	1098		80	7550	55	14,2	90
						630	80		/		83
						630	80		/		83

 Teklif isteyiniz.

Performans Şeması / Performance diagram

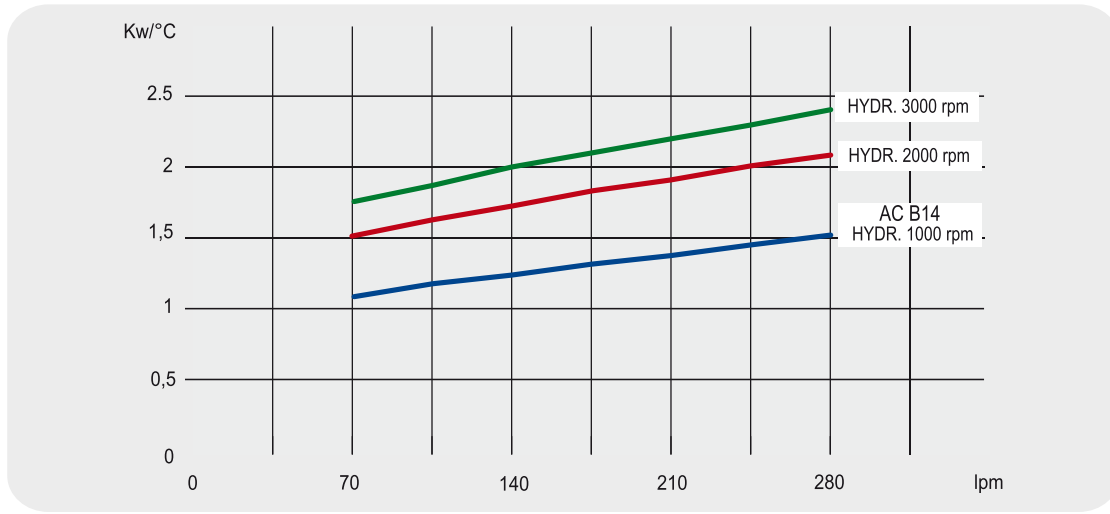

Basınç Düşmesi / Pressure drop (ISO VG 32)

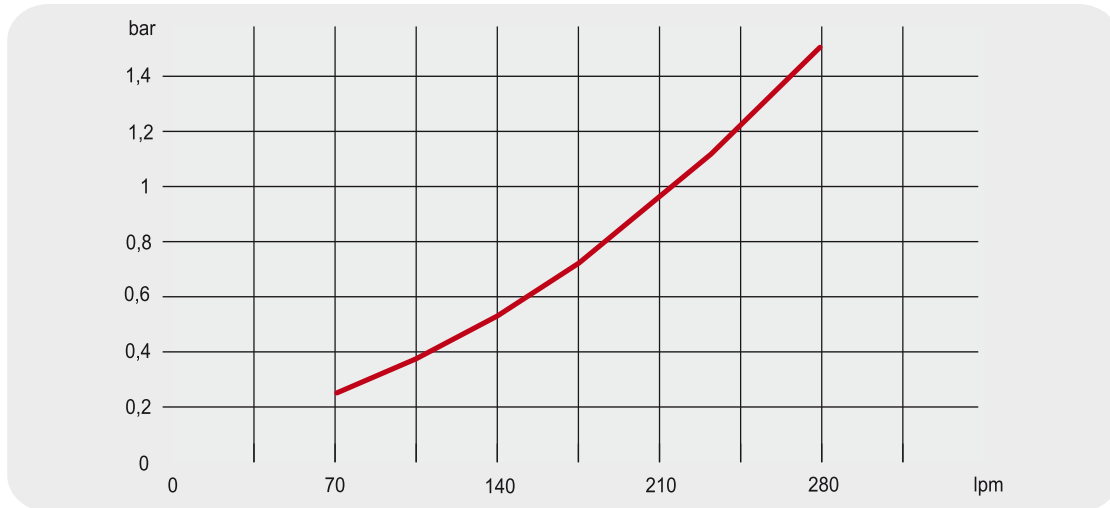

Düzeltilme Faktörü -F- (Basınç Düşmesi) / Correction factor -F- (Pressure drop)

cst	10	15	20	30	40	50	60	80	100	200	300
F	0,5	0,65	0,77	1	1,2	1,4	1,6	1,9	2,1	3,3	4,3



Yağ Soğutucu Boyutları / Dimensions

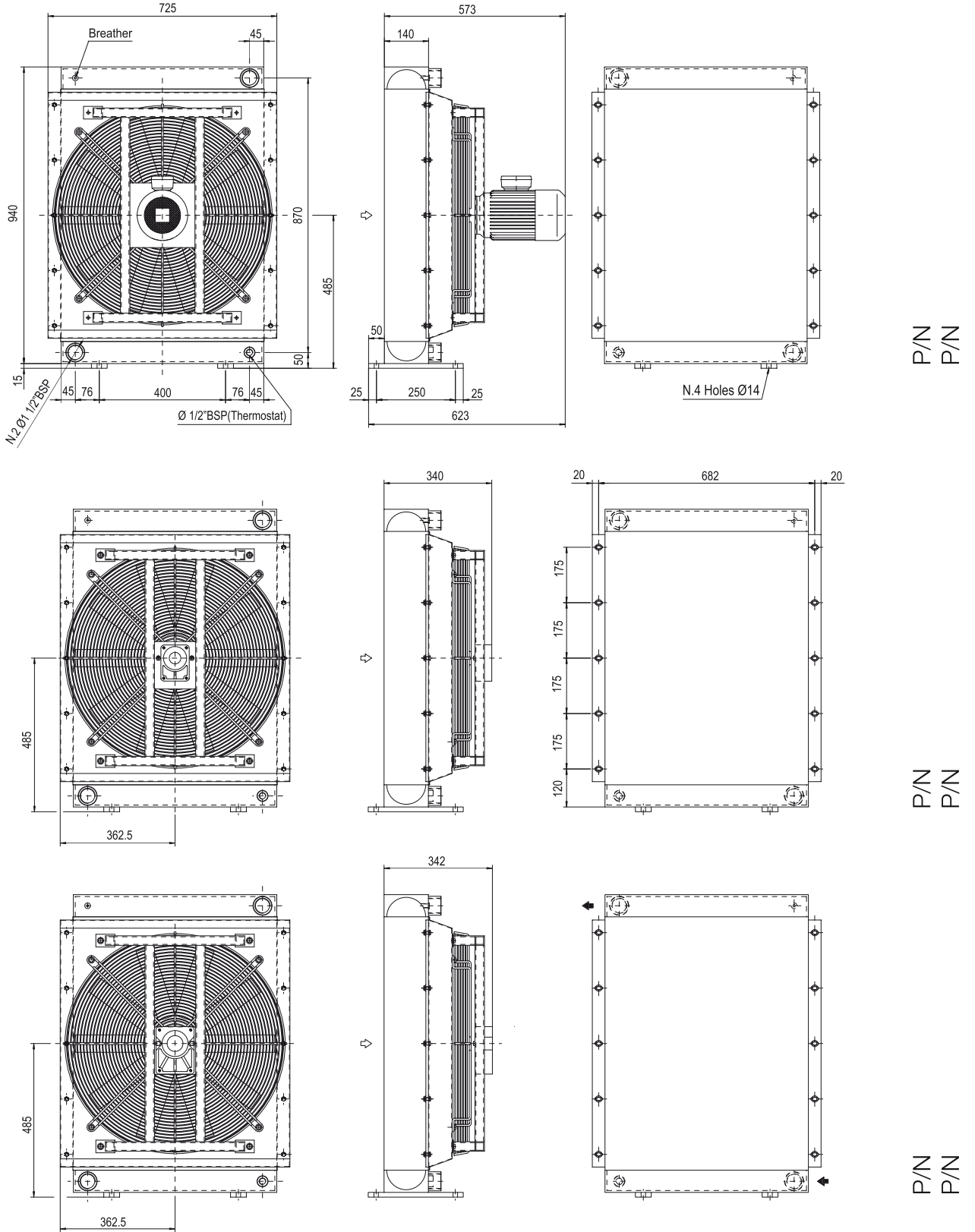

P/N
P/N

P/N
P/N

P/N
P/N

Boyutlar ve teknik özellikler bağlayıcı değildir.
Over-all dimensions and technical characteristic are not binding

Teknik Veriler / Technical Data

P/N	V	Hz	kW	A	rpm	ø Fan	dB(A)	(m ³ /h)	IP	lt	Kg
	230-400 B14 AC	50	1,1	4,77-2,74	915		80	7050			
	280-480 B14 AC	60	1,32	4,70-2,74	1098	630	☒	☒	55	17,7	95
					☒	630	☒	☒	/		89
					☒	630	☒	☒	/		89

☒ Teklif isteyiniz.

Performans Şeması / Performance diagram

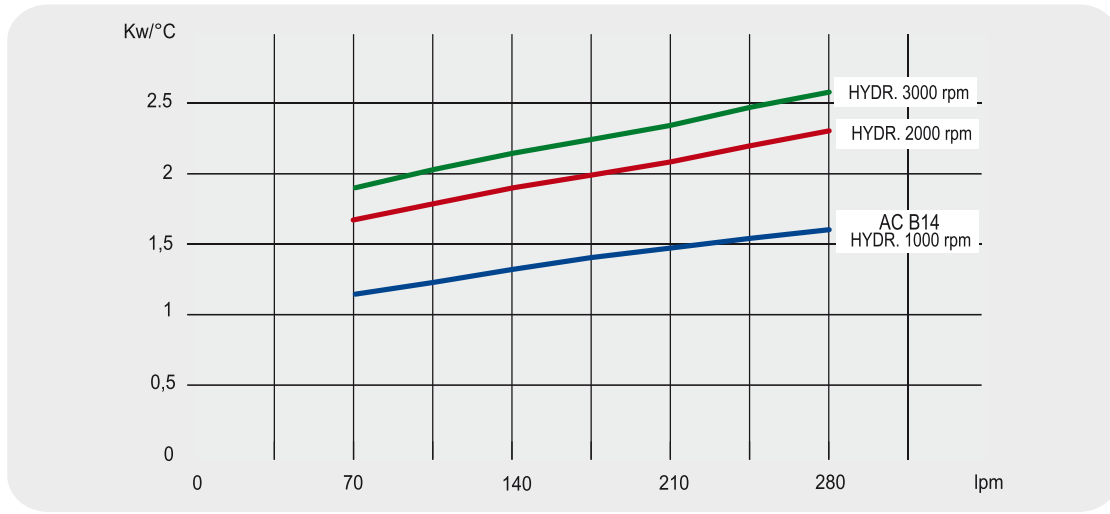

Basınç Düşmesi / Pressure drop (ISO VG 32)

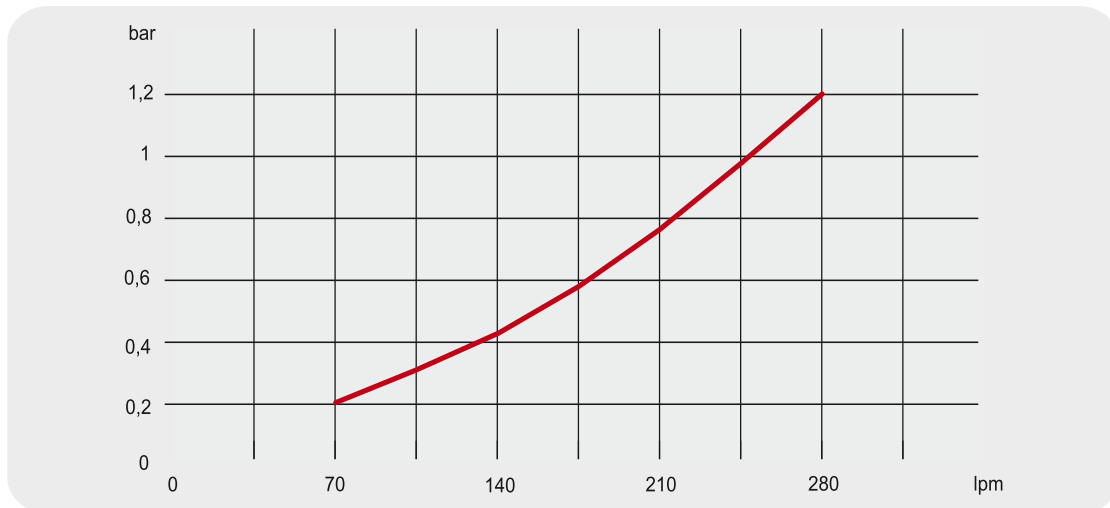

Düzeltilme Faktörü -F- (Basınç Düşmesi) / Correction factor -F- (Pressure drop)

cst	10	15	20	30	40	50	60	80	100	200	300
F	0,5	0,65	0,77	1	1,2	1,4	1,6	1,9	2,1	3,3	4,3

CHR®

COOLER HEAT EXCHANGER RADIATOR

1985'DEN İTİBAREN YAĞ SOĞUTUCU İMALATI



BAŞKENT RADIATÖR KAYNAK
YAĞ SOĞUTUCU MAK. METAL OTO. İNŞ. SAN. ve TİC. LTD. ŞTİ.

MERKEZ

OSTİM OSB MAHALLESİ BAĞDAT CADDESİ 1168. SOKAK NO:17-19 OSTİM / ANKARA / TURKEY

@ www.chr.com.tr / www.baskentradiyator.com

+90 312 354 18 60

info@chr.com.tr / info@baskentradiyator.com

+90 312 354 45 66

+90 532 063 07 46

FABRİKA

UZAY ÇAĞI BULVARI 1165. SK.
OSTİM / ANKARA



SERVİS BAKIM

BAĞDAT CADDESİ 1168. SK.
NO:20 OSTİM / ANKARA